

### Iron Gate Valves

PN16/235PSI/Class125

Non-Rising Stem, Solid Wedge, Bronze Seat  
 Design to BS5150 and MSS SP-70  
 Flange Dimension to EN1092-2, ANSI B16.1 Class 125

Hydraulic Pressure Test	
Body	2.4Mpa/24Bar
Seat	1.76Mpa/17.6Bar

Pressure Ratings	
	1.0 Mpa at 180°C
	1.6 Mpa at -10°C-120°C



**MG670-N**  
2" - 24"

#### Materials List

No	Part	Specification	BS EN	ASTM
1	Body	Cast Iron	BSEN 1561	A126 Class B
2	Seat Sealing Ring	Cast Bronze	1982 CC491K	B62
3	Disc Sealing Ring	Cast Bronze	1982 CC491K	B62
4	Disc	Cast Iron	BSEN 1561	A126 Class B
5	Stem Nut	Brass	12164 CW603N	B16
6	Stem	Brass	12164 CW603N	B16
7	Gasket	Graphite	---	--
8	Bolt	Steel	BSEN 10087	Steel A307
9	Nut	Steel	BSEN 10087	Steel A307
10	Bonnet	Cast Iron	BSEN 1561	A126 Class B
11	Stud	Steel	BSEN 10087	Steel A307
12	Nut	Steel	BSEN 10087	Steel A307
13	Gland Box Gasket	Graphite	---	--
14	Gland Box	Cast iron	BSEN 1561	A126 Class B
15	Packing	Graphite	---	--
16	Seal Gland	Ductile Iron	BSEN 1563	A536 65-45-12
17	Handwheel	Cast Iron	BSEN 1561	A126 Class B
18-19	Gasket	Steel	BSEN 10087	Steel A307
20	Nut	Steel	BSEN 10087	Steel A307

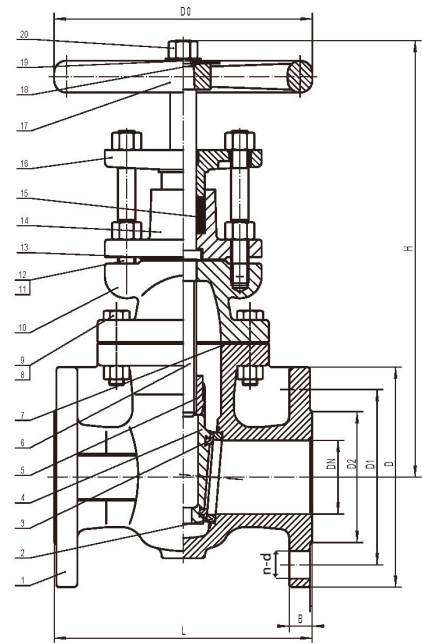

#### Dimensions-Weights

mm	50	65	80	100	125	150	200	250	300	350	400	450	500	600	
In	2	2½	3	4	5	6	8	10	12	14	16	18	20	24	
L	178	190	203	229	254	267	292	330	356	381	406	432	457	508	
H	302	332	335	423	485	545	644	769	860	987	1044	1148	1257	1418	
D	165	185	200	220	250	285	340	405	460	520	580	640	715	840	
D1	125	145	160	180	210	240	295	355	410	470	525	585	650	770	
D2	99	118	132	156	184	211	266	319	370	429	480	548	609	720	
D0	178	178	200	254	300	300	348	400	457	560	560	610	610	765	
B	20	20	22	24	26	26	30	32	32	36	38	40	42	48	
n-d	4-19	4-19	8-19	8-19	8-19	8-23	12-23	12-28	12-28	16-28	16-31	20-31	20-34	20-37	
Weight	Lbs	36	48	58	104	150	192	260	434	606	816	1039	1400	1764	2646
	Kg	17	22	27	47	68	87	118	197	275	370	471	635	800	1200